

Product Installation Guidelines

Version 1, 16 November 2023 Page 1 of 17
Document No.: 001.00.30.11

GalvinLab® CP-BS Lead Safe Lab Set Tapware



PRODUCTS

Item Code	Description	WELS Rating	Water Consumption	Nominal Flow Rate	Outlet	Headworks
167.05.21.00	Galvinlab® CP-BS Lead Safe Lab Set 1-Way Type 5 Fixed J/V #16XT Tube Nozzle	5	5.5	5.3	Tube Nozzle	Jumper Valve
167.05.22.00	Galvinlab® CP-BS Lead Safe Lab Set 1-Way Type 5 Fixed J/V #16XT Tube Nozzle	5	5.5	5.3	Aerator	Jumper Valve
167.06.21.00	Galvinlab® CP-BS Lead Safe Lab Set 2-Way Type 6 Fixed J/V #16XT Tube Nozzle	5	6.0	6.0	Tube Nozzle	Jumper Valve
167.07.20.00	Galvinlab® CP-BS Lead Safe Lab Set 3-Way Type 7 Fixed J/V #1 Aerator & #16XT Tube Nozzle	6*	4.5	4.4	Aerator & Tube Nozzle	Jumper Valve
167.07.11.00	Galvinlab® CP-BS Lead Safe Lab Set 3-Way Type 7 Swivel J/V #16XT Tube Nozzle	4	6.5	6.3	Tube Nozzle	Jumper Valve
167.08.10.00	Galvinlab® CP-BS Lead Safe Lab Set 2-Way Type 8 Swivel J/V #1 Aerator & #16XT Tube Nozzle	5	5.0	5.0	Aerator & Tube Nozzle	Jumper Valve
167.08.30.00	GalvinLab® CP-BS Lead Safe Lab Set 2-Way Type 8 DPW Fixed J/V #8 V/R Aerator, #16XT Tube Nozzle 5LPM	4	6.5	6.3	Aerator & Tube Nozzle	Jumper Valve
167.08.11.00	Galvinlab® CP-BS Lead Safe Lab Set 2-Way Type 8 Swivel J/V #16XT Tube Nozzle	4	6.5	6.3	Tube Nozzle	Jumper Valve
167.13.11.00	Galvinlab® CP-BS Lead Safe™ Lab Set H&C Mixing Unit Type 13 Swivel J/V #16XT Tube Nozzle	6*	4.5	4.36	Tube Nozzle	Jumper Valve
167.13.12.00	Galvinlab® CP-BS Lead Safe™ Lab Set H&C Mixing Unit Type 13 Swivel J/V #1 Aerator	6*	4.5	4.36	Tube Nozzle	Jumper Valve
167.14.11.00	Galvinlab® CP-BS Lead Safe Lab SET H&C Mixing Unit Type 14 Swivel J/V #16XT Tube Nozzle	6*	4.0	3.75	Tube Nozzle	Jumper Valve
167.14.20.00	Galvinlab® CP-BS Lead Safe Lab Set H&C Mixing Unit Type 14 Fixed J/V Aerator #1 & #16XT Tube Nozzle	4	6.5	6.3	Aerator & Tube Nozzle	Jumper Valve
167.14.12.00	Galvinlab® CP-BS Lead Safe Lab Set H&C Mxing Unit Type 14 Swivel J/V #1 Aerator - MTO	5	5.5	5.45	Aerator & Tube Nozzle	Jumper Valve
167.16.11.00	GalvinLab® CP-BS Lead Safe™ Lab Set 1-Way Type 16 Swivel J/V #16XT Tube Nozzle	6*	4.5	4.49	Tube Nozzle	Jumper Valve
167.16.12.00	GalvinLab® CP-BS Lead Safe™ Lab Set 1-Way Type 16 Swivel J/V #1 Aerator	6*	4.5	4.49	Aerator	Jumper Valve

PRODUCTS						
Item Code	Description	WELS Rating	Water Consumption	Nominal Flow Rate	Outlet	Headworks
167.16.15.00	GalvinLab® CP-BS Lead Safe™ Lab Set 1-Way Type 16 Swivel C/D #16 Xt Tube Nozzle [MTO]	5	6.0	5.6	Tube Nozzle	Ceramic Disc
167.16.21.00	GalvinLab® CP-BS Lead Safe™ Lab Set 1-Way Type 16 Fixed J/V #16Xt Tube Nozzle	6*	4.5	4.49	Tube Nozzle	Jumper Valve
167.16.21.01	GalvinLab® CP-BS Lead Safe™ Lab Set 1-Way Type 16 Fixed J/V Lever Han	6*	4.5	4.49	Tube Nozzle	Jumper Valve
167.16.22.00	Galvinlab® CP-BS Lead Safe™ Lab Set 1-Way Type 16 Fixed J/V #1 Aerator	6*	4.5	4.49	Aerator	Jumper Valve
167.16.27.00	GalvinLab® CP-BS Lead Safe™ Lab Set 1-Way Type 16 Fixed J/V Tube Nozzle - LH	6*	4.5	4.49	Tube Nozzle	Jumper Valve
167.16.27.01	GalvinLab® CP-BS Lead Safe™ Lab Set 1-Way Type 16 Fixed J/V Lever Handle Tube Nozzle - LH	6*	4.5	4.49	Tube Nozzle	Jumper Valve
167.16.31.00	Galvinlab® CP-BS Lead Safe™ Lab Set 1-Way Type 16 DPW Fixed J/V #16XT Tube Nozzle	6*	4.5	4.49	Tube Nozzle	Jumper Valve
167.16.32.00	Galvinlab® CP-BS Lead Safe™ Lab Set 1-Way Type 16 Dpw Fixed J/V #8 V/R Aerator	6*	4.5	4.49	Aerator	Jumper Valve
167.16.32.01	GalvinLab® CP-BS Lead Safe™ Lab Set 1-Way Type 16 Fixed J/V Lever Handle PWD #8 V/R Aerator	5	6.0	5.6	Aerator	Jumper Valve
167.16.33.00	GalvinLab® CP-BS Lead Safe™ Lab Set 1-Way Type 16 Dpw Fixed J/V #8 V/R Aerator - LH	6*	4.5	4.49	Aerator	Jumper Valve
167.16.42.00	GalvinLab® CP-BS Lead Safe™ Lab Set 1-Way Type 16 Upswept Swivel J/V #1 Aerator	5	6.0	5.6	Aerator	Jumper Valve
167.16.72.00	GalvinLab® CP-BS Lead Safe™ Wall Mounted 1-Way Type 16 Fixed J/V #8 V/R Aerator	5	6.0	5.6	Aerator	Jumper Valve
167.17.21.00	GalvinLab® CP-BS Lead Safe™ Lab Set 1-Way R/A Valve Type 17 Fixed J/V #16Xt Tube Nozzle	5	6.0	5.6	Tube Nozzle	Jumper Valve
167.19.11.00	Galvinlab® CP-BS Lead Safe™ Lab Set H&C Mixing Unit Type 19 Swivel J/V #16XT Tube Nozzle	6*	4.5	4.36	Tube Nozzle	Jumper Valve
167.19.12.00	Galvinlab® CP-BS Lead Safe™ Lab Set H&C Mixing Unit Type 19 Swivel J/V #1 Aerator	6*	4.5	4.36	Aerator	Jumper Valve
167.26.32.00	Galvinlab® CP-BS Lead Safe™ Lab Set Bib Tap Bench Mtd Type 26 DPW Fixed J/V #8 V/R Aerator	6*	3.5	3.06	Aerator	Jumper Valve
167.26.32.01	Galvinlab® CP-BS Lead Safe™ Lab Set Bib Tap Bench Mtd Type 26 J/V Lever Handle #8 V/R Aerator	5	5.5	5.3	Aerator	Jumper Valve
167.54.32.00	L/Action CP-BS Lead Safe Surg Bench Mounted Type 54 DPW Fixed J/V #8 Aer 5LPM	5	5.5	5.3	Aerator	Jumper Valve

*Components are dual-star rated. See "Dual-Star Rated Items" table for more information

SPECIFICATIONS

- Chrome plate finish for easy cleaning and durability.
- Replaceable top assemblies are supplied for easy maintenance.
- Simple servicing and readily available parts.
- Quality controlled. Every tap is tested.
- Lead Safe™ brass construction*.

IMPORTANT: All laboratory taps are tested in accordance with AS/NZS 3718 and leave our premises in good working order.

*Our Lead Safe™ product range is compliant with the Lead Free Requirements of the NCC 2022 Vol. Three, Clause A5G4(2) and NSF/ANSI 372.

WARNINGS: Special attention to be paid on notes, photos, images, or drawings of assembly steps marked with the warning symbol.



TECHNICAL DATA

Inlet	1/2" BSP - Male	
Working Pressure Range (kPa)	Min	50
	Max	500
Working Temperature Range (°C)	Min	5
	Max	65
Construction	Brass	
Finish	Chrome	
NOTE: Galvin Engineering continually strive to improve their products. Specifications may change without notice.		

TOOLS REQUIRED

- Power drill	- Spanner or adjustable crescent	- Thread tape / sealant
---------------	----------------------------------	-------------------------

DIMENSIONS

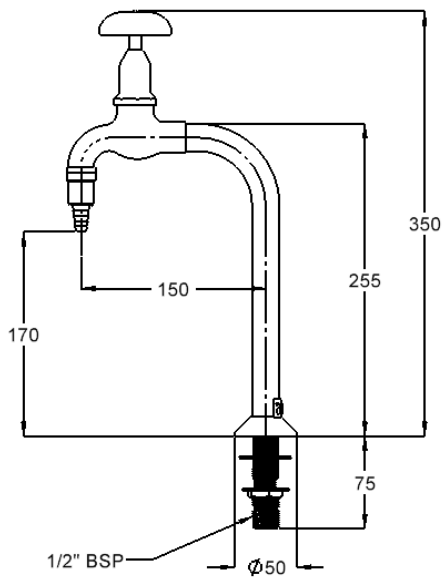

167.05.21.00

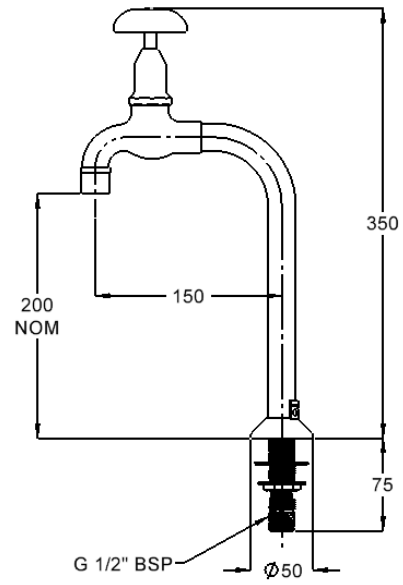

167.05.22.00

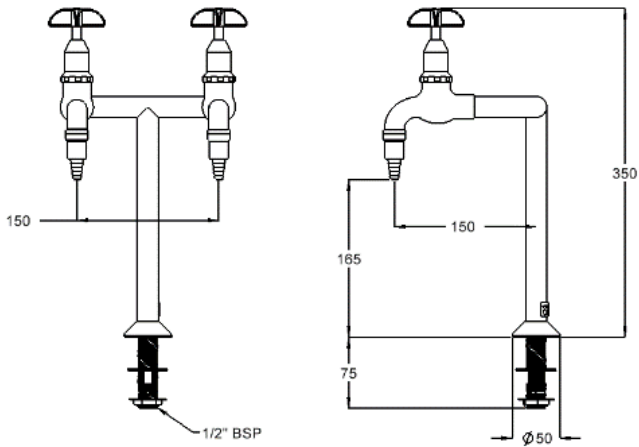

167.06.21.00

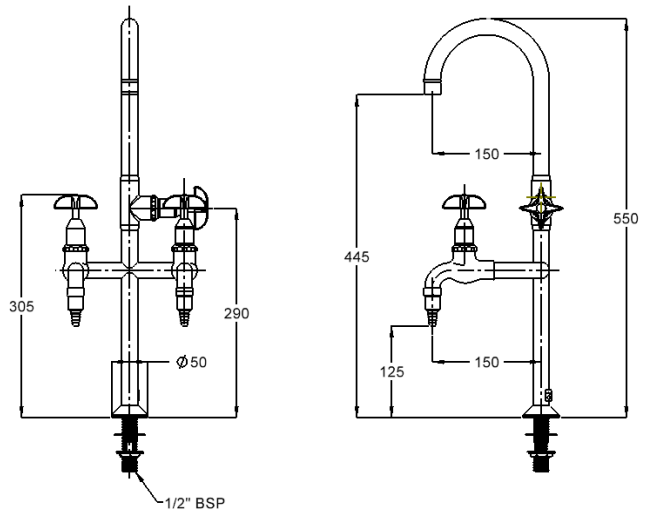

167.07.20.00

DIMENSIONS

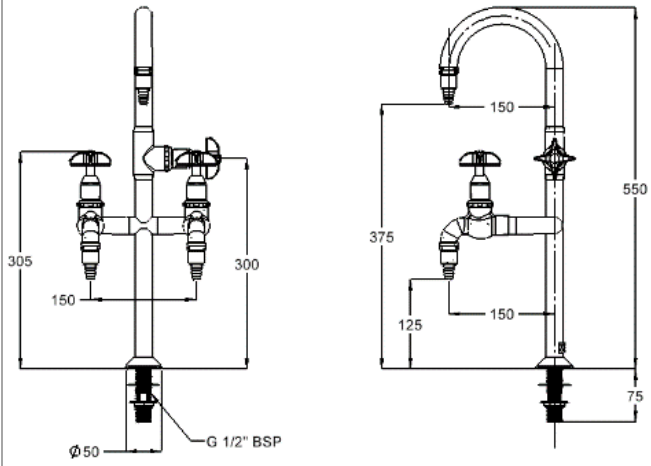

167.07.11.00

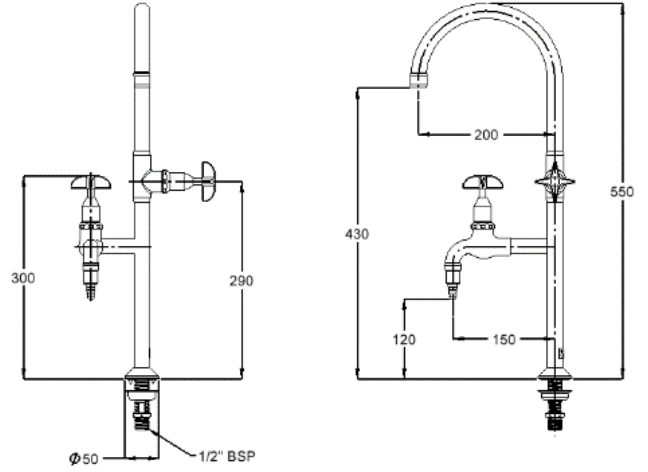

167.08.30.00

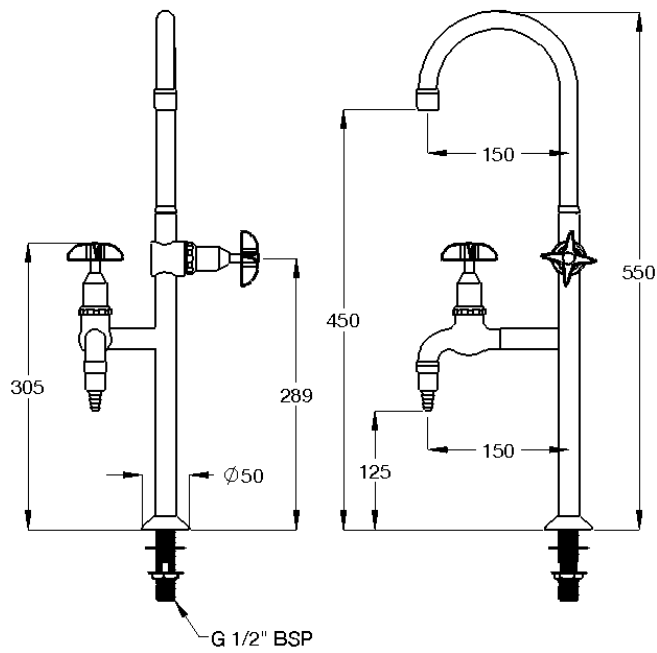

167.08.10.00

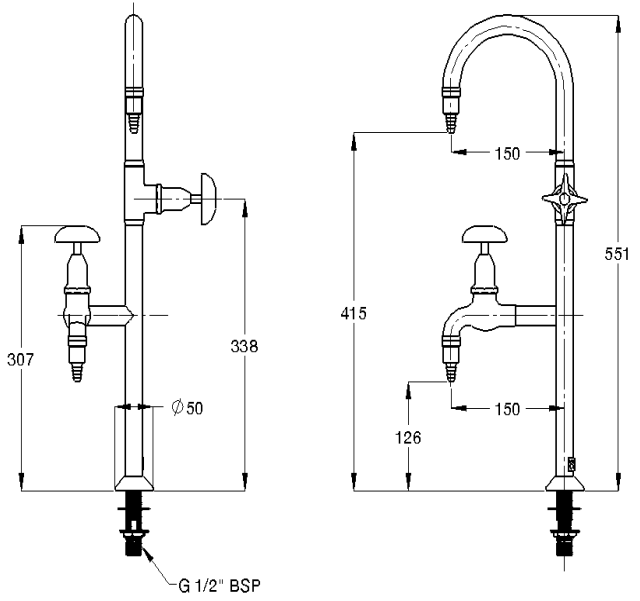

167.08.11.00

DIMENSIONS

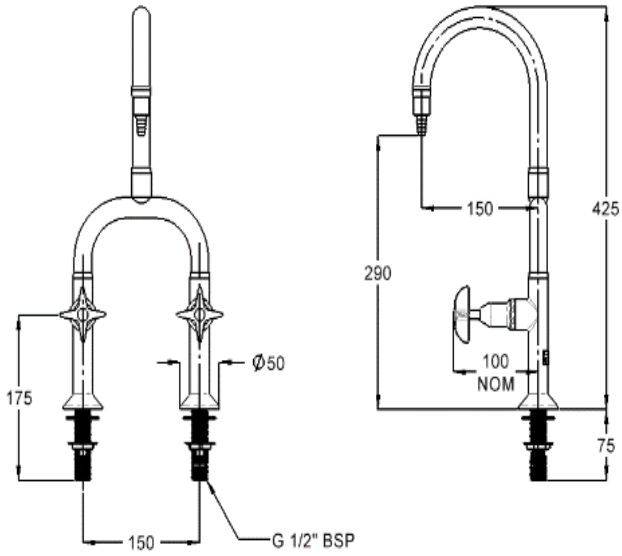

167.13.11.00

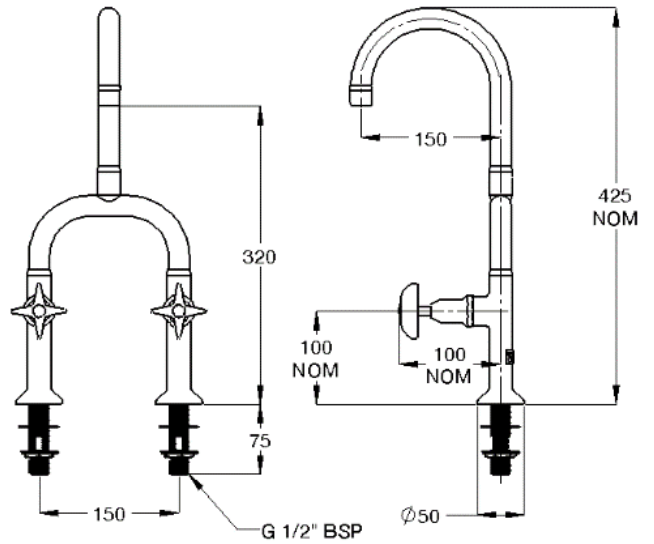

167.13.12.00

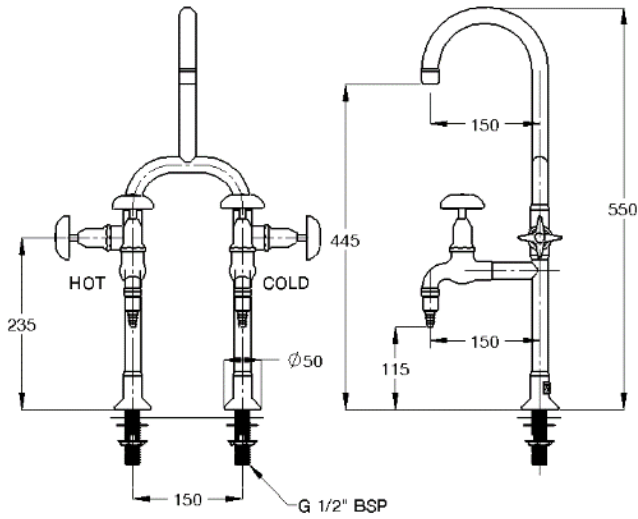

167.14.20.00

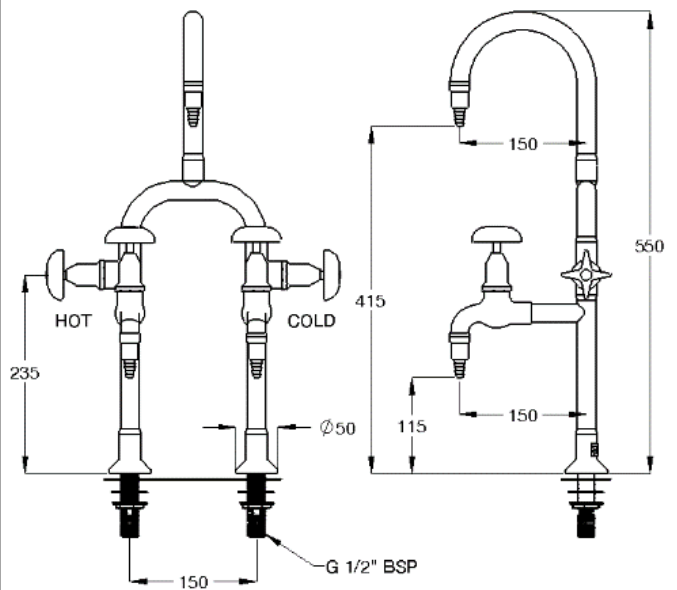

167.14.11.00

DIMENSIONS

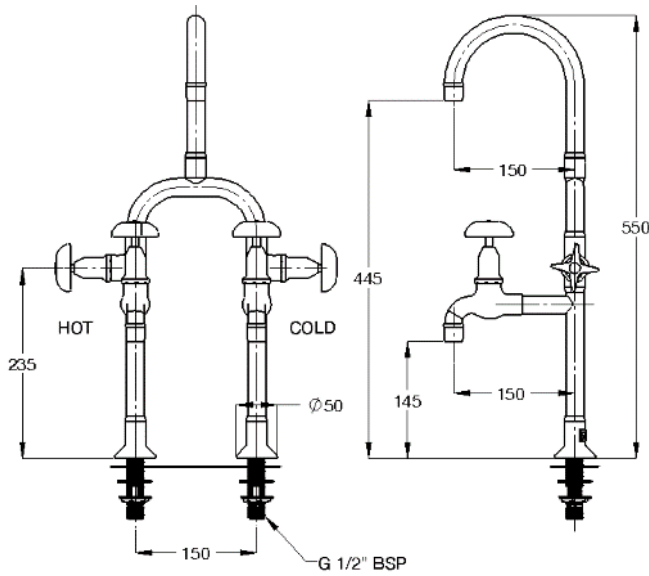

167.14.12.00

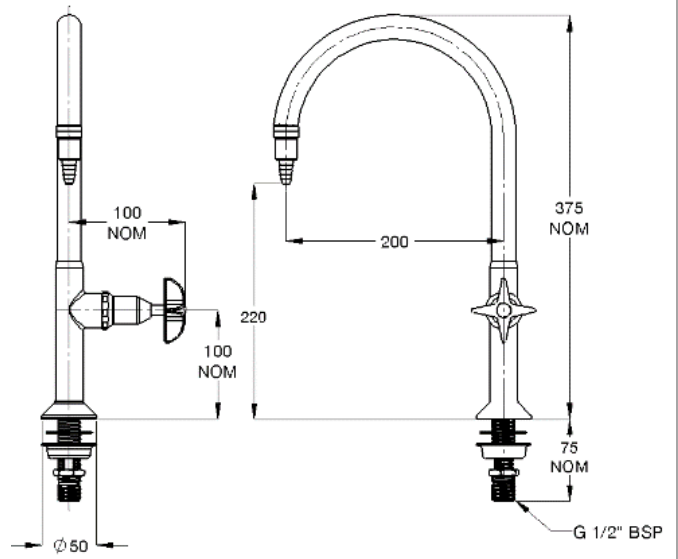

167.16.31.00

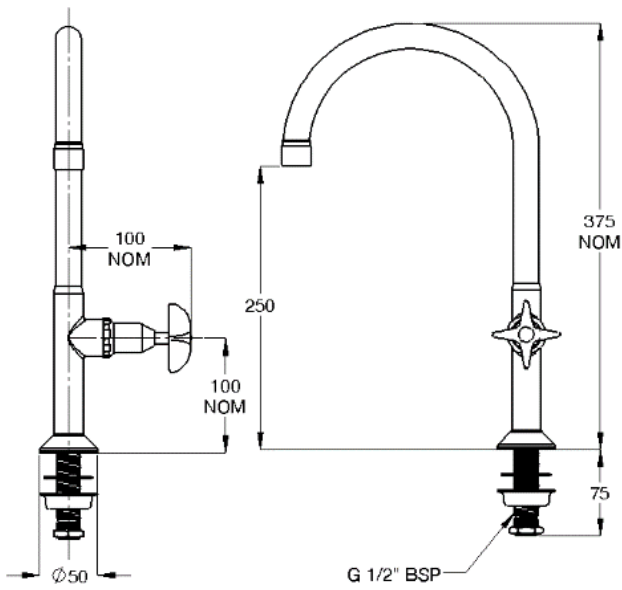

167.16.32.00

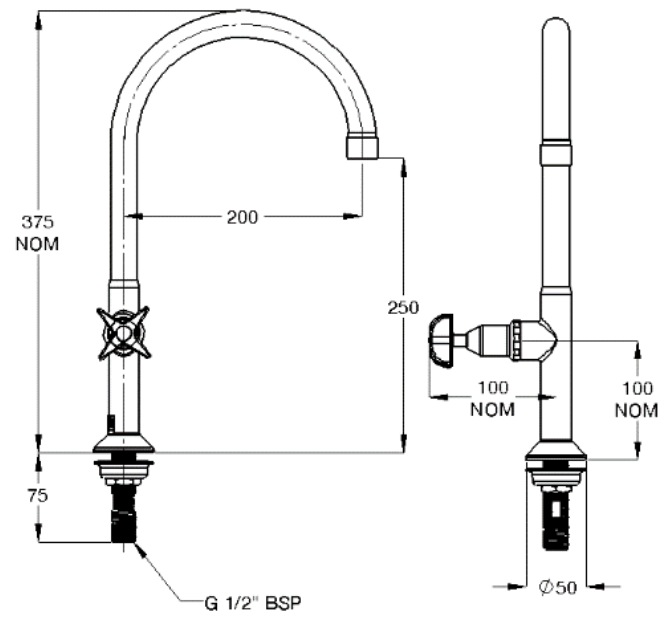

167.16.33.00

DIMENSIONS

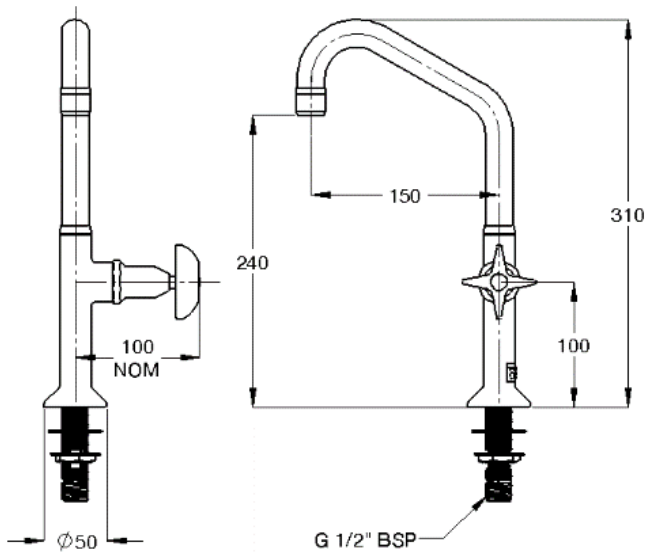

167.16.42.00

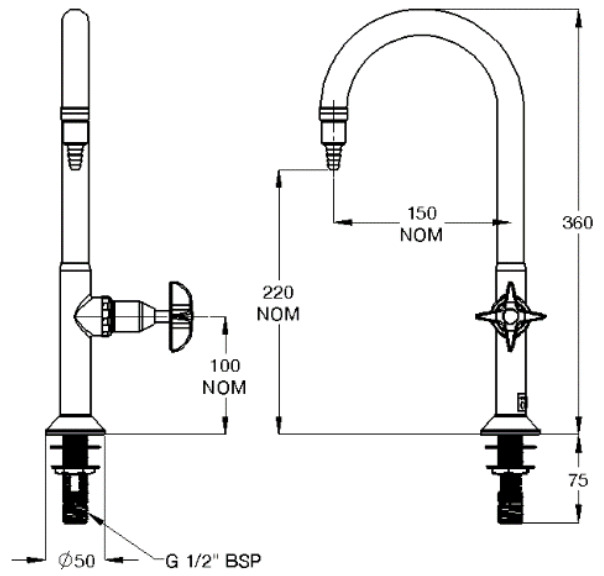

167.16.21.00

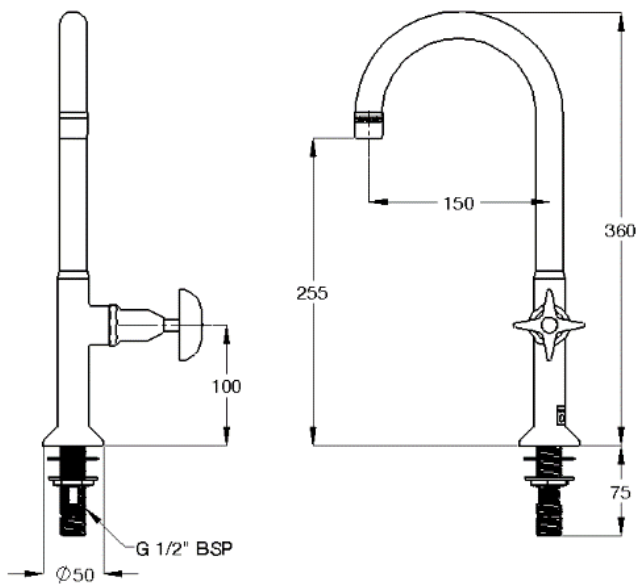

167.16.22.00

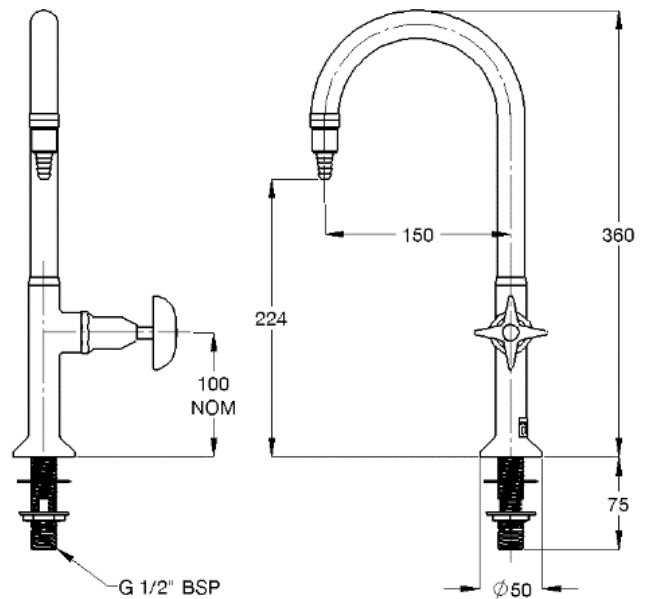

167.16.15.00

DIMENSIONS

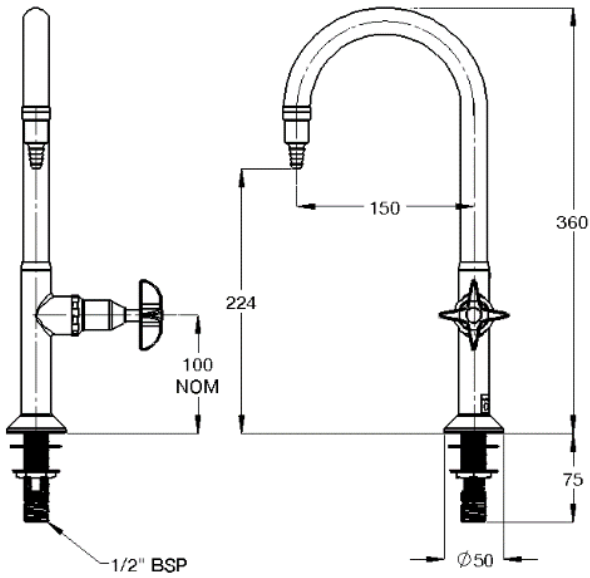

167.16.11.00

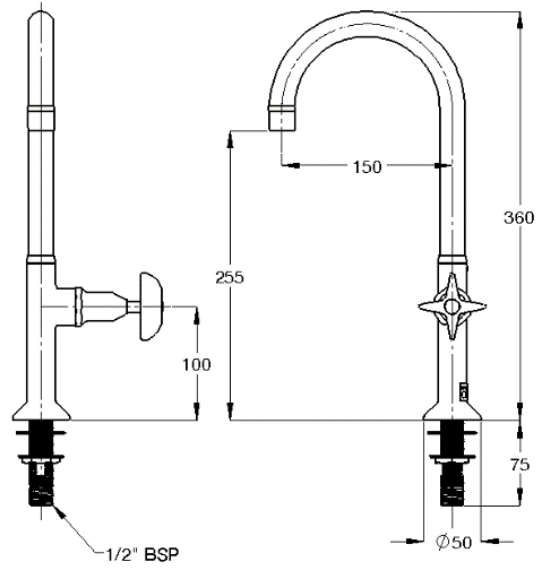

167.16.12.00

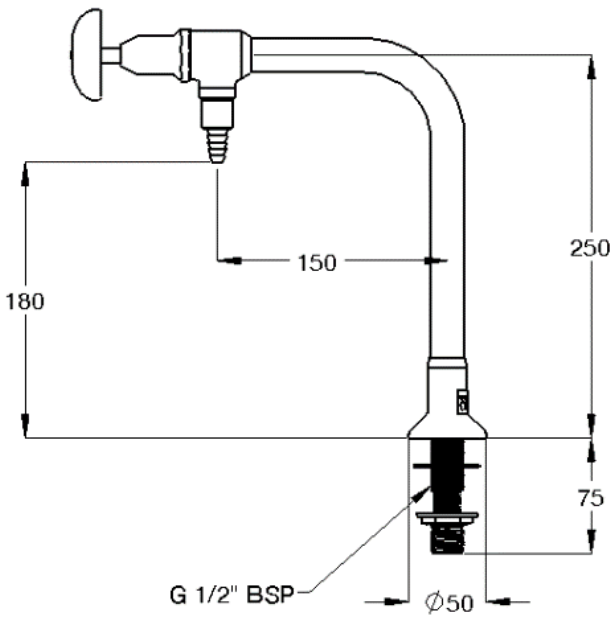

167.17.21.00

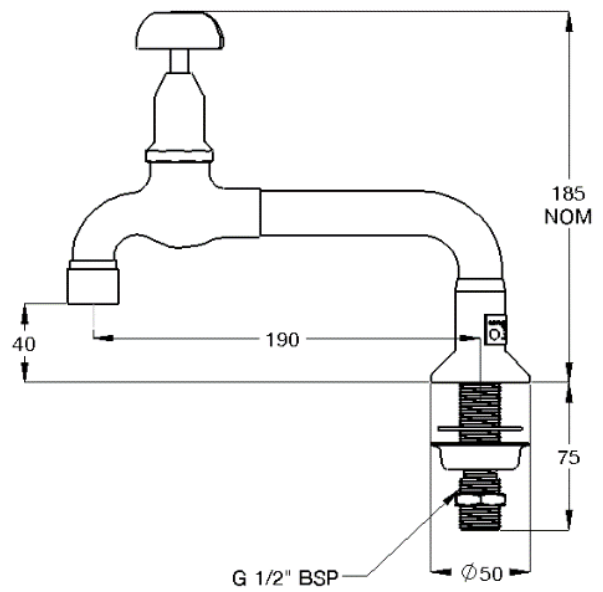

167.26.32.00

DIMENSIONS

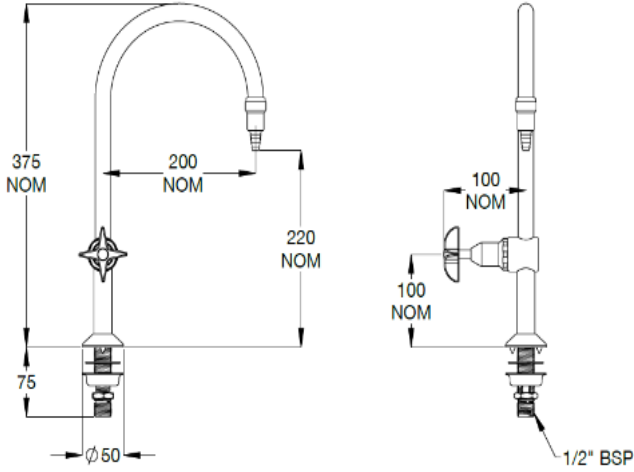

167.16.27.00

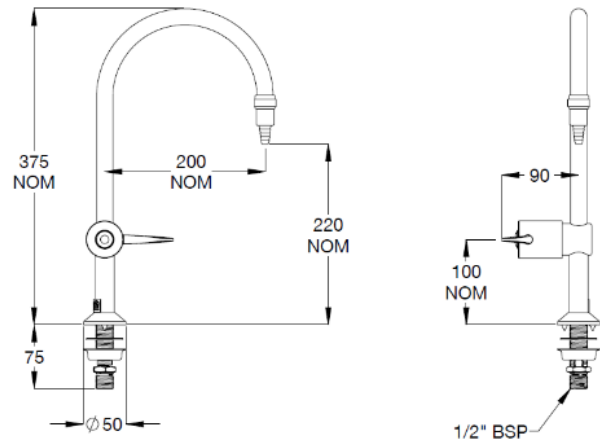

167.16.27.01

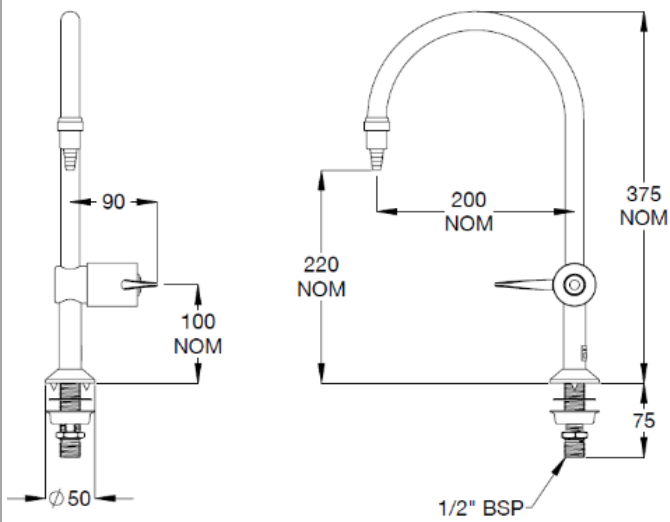

167.16.21.01

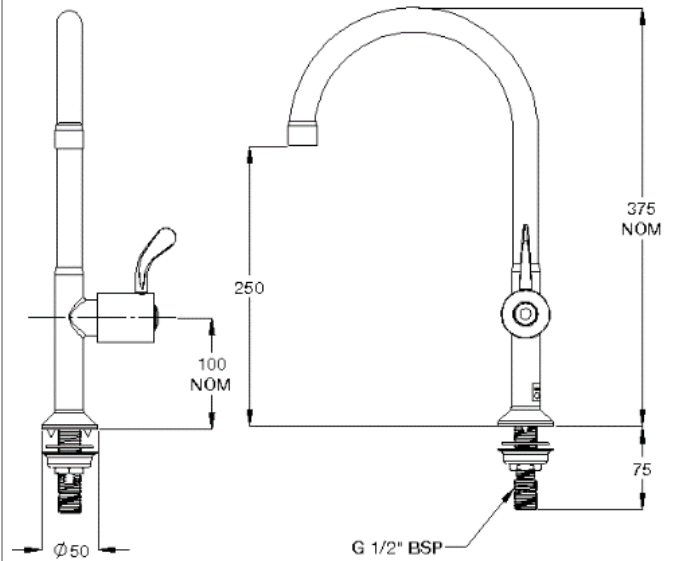

167.16.32.01

DIMENSIONS

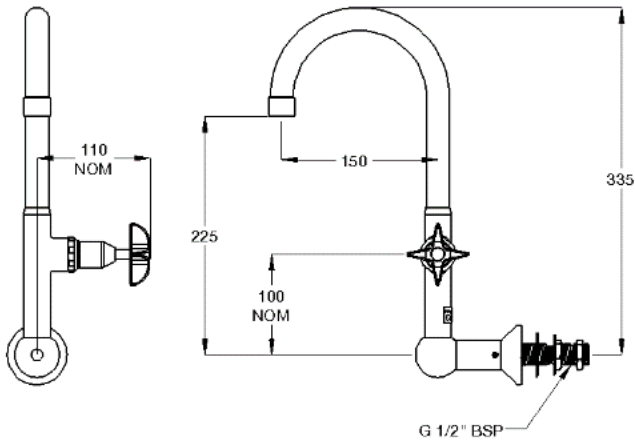

167.16.72.00

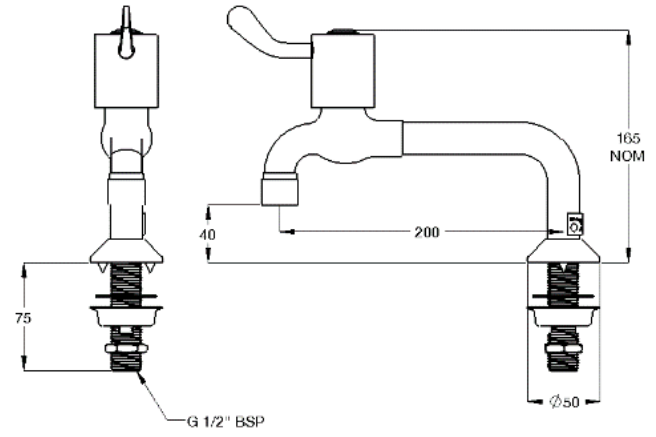

167.26.32.01

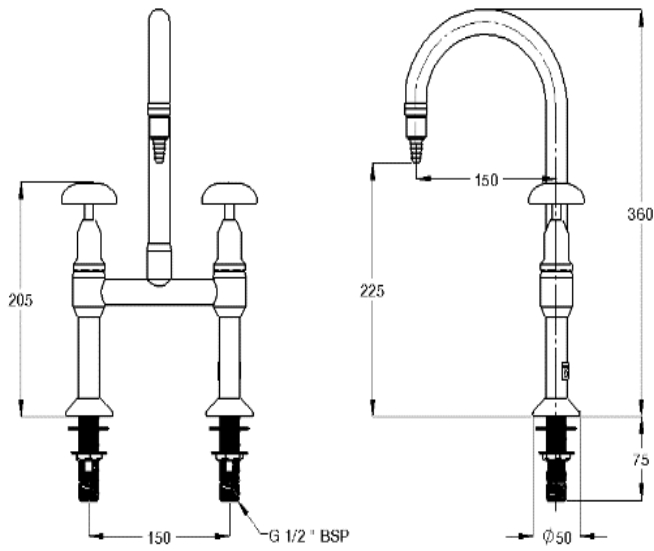

167.19.11.00

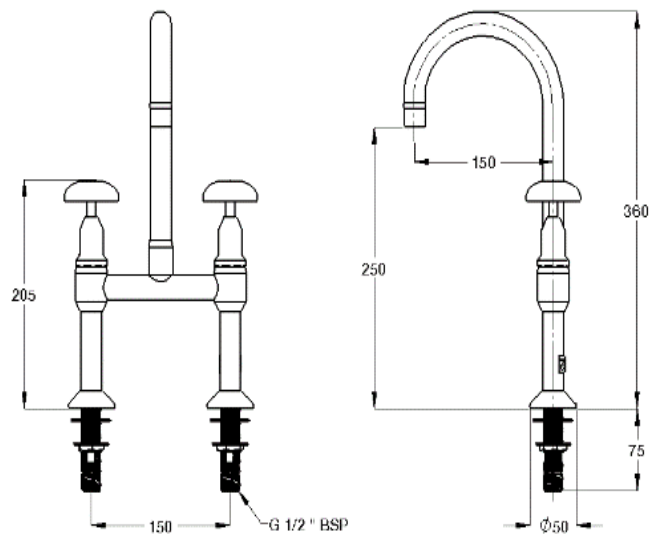

167.19.12.00

DIMENSIONS

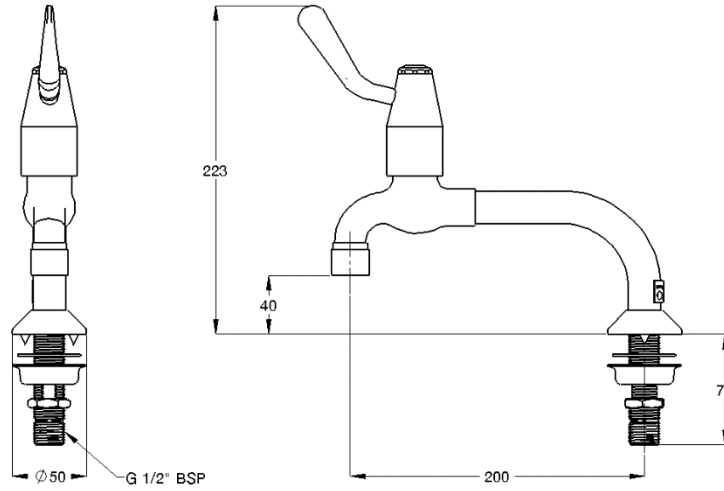

167.54.32.00

PRE-INSTALLATION

- Before installation, all lines must be flushed.
- Galvin Engineering recommends the installation of strainers and pressure reducing valves (when necessary) to ensure clean consistent supply. Debris or poor water quality could affect the performance of the unit.
- If the mounting hole does not already exist, mark out and drill the holes on the bench, as shown in rough-in dimensions.

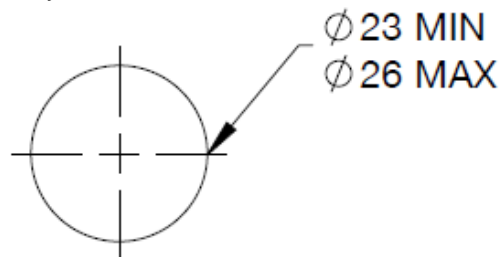

⚠ ROUGH-IN DIMENSIONS

INSTALLATION

INSTALLATION COMPLIANCE: Galvin Engineering products must be installed in accordance with these installation instructions and in accordance with AS/NZS 3500, the PCA and your local regulatory requirements. Water and/or electrical supply conditions must also comply to the applicable national and/or state standards. Failing to comply with these provisions shall void the product warranty and may affect the performance of the product.

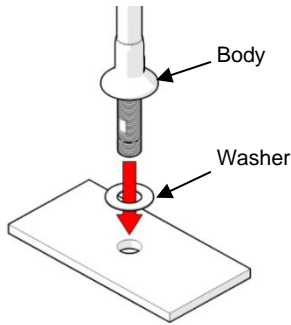

1. Fit lab set body

- Fit the lab set into the bench.
- Fit the rubber washer underneath the stem.

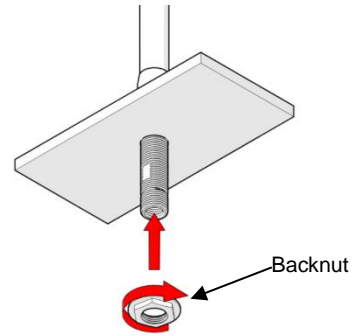

2. Secure the body

- Secure the body underneath with the supplied backnut.

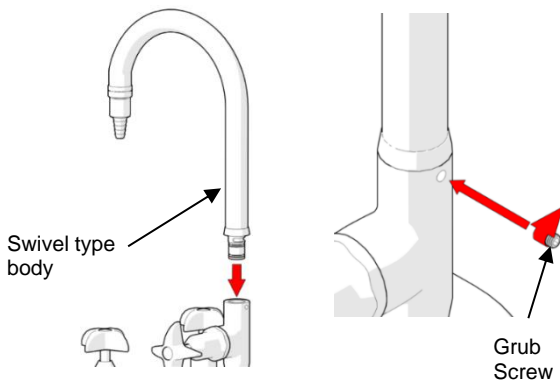

3. Insert Outlet (Swivel Body)

- If tap is swivel type, insert spout to the body and secure with grub screw.
- For fixed taps, outlet is already connected to the body.

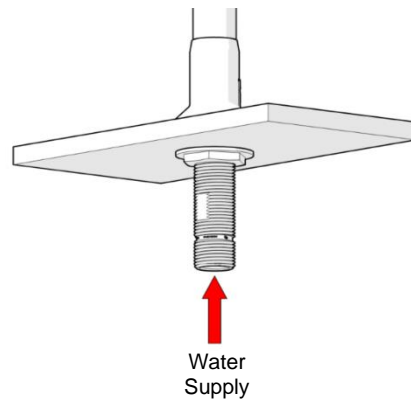

4. Connect the water line

- Connect water supply ensuring thread tape / sealant is used.

5. Testing

- Inspect the tap and check for any leaks.

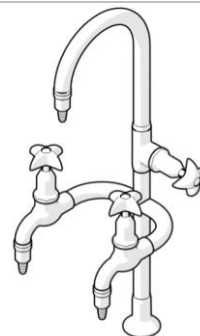

Dual-Star Rated Items (WELS)

Due to some state requirements, items are required to be in higher star rating (6-star). Therefore, for some items, two flow regulators are supplied. Primarily, the higher star-rated flow regulator is equipped in the assembly.

Items	Primary Flow Regulator	Alternative Flow regulator
167.13.11.00	6-stars (pink)	5-stars (red)
167.13.12.00	6-stars (pink)	5-stars (red)
167.16.21.01	6-stars (pink)	5-stars (red)
167.16.27.01	6-stars (pink)	5-stars (red)
167.16.31.00	6-stars (pink)	5-stars (red)
167.16.32.00	6-stars (pink)	5-stars (red)
167.16.33.00	6-stars (pink)	5-stars (red)
167.16.21.00	6-stars (pink)	5-stars (red)
167.16.22.00	6-stars (pink)	5-stars (red)
167.16.11.00	6-stars (pink)	5-stars (red)
167.16.12.00	6-stars (pink)	5-stars (red)
167.16.27.00	6-stars (pink)	5-stars (red)
167.19.11.00	6-stars (pink)	5-stars (red)
167.19.12.00	6-stars (pink)	5-stars (red)
167.26.32.00	6-stars (blue)	5-stars (orange)
167.07.20.00	6-stars (pink)	5-stars (red)
167.14.11.00	6-stars (pink)	5-stars (red)

REPLACING FLOW REGULATOR (EXCET 167.26.32.00)

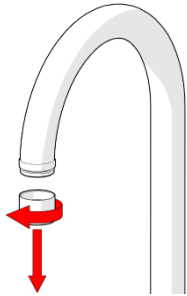

1. Remove Aerator Housing

- Turn housing to loosen and to remove as shown. For vandal-resistant type, use supplied tool to remove housing.

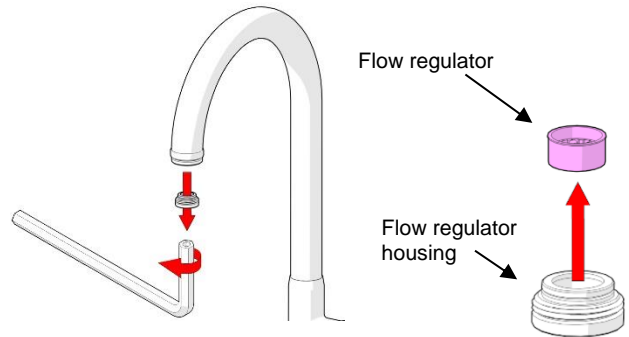

2. Remove & Swap

- Using a hex key, remove the secondary housing from the gooseneck.
- Push out the flow regulator from the housing.
- Fit the supplied alternative flow regulator.

Note: Not all items have supplied alternative flow regulators. If required, please contact Galvin Engineering.

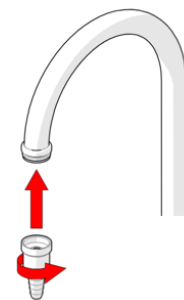
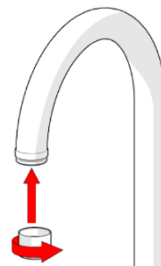
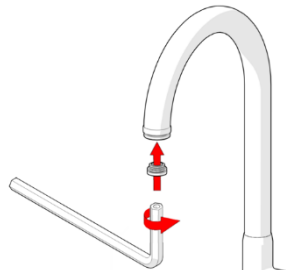
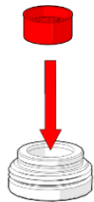

3. Reassemble

- Reverse steps 2 & 1 to reassemble ensuring correct orientation.
- Test for leaks and correct operation

REPLACING FLOW REGULATOR (FOR 167.26.32.00)



1. Remove Aerator Housing

- Turn housing to loosen and to remove as shown.

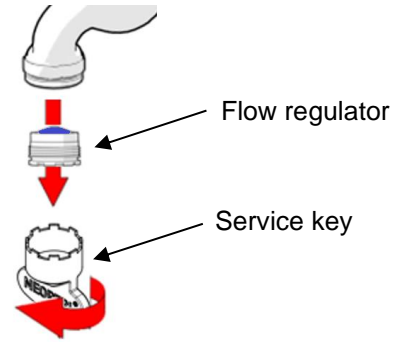

2. Remove & Swap

- Match the grooves of the service key with the aerator.
- Turn the key to loosen and to remove aerator.
- Fit the supplied alternative flow regulator.

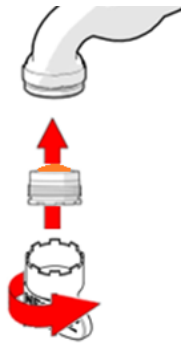

3. Reassemble

- Reverse steps 2 & 1 to reassemble ensuring correct orientation.
- Test for leaks and correct operation

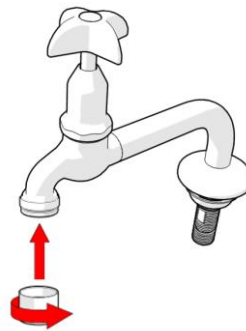

TROUBLESHOOTING

PROBLEM	CAUSE	RECTIFICATION
Water is not flowing or inconsistent flow	Blocked tube nozzle	Remove tube nozzle from outlet and remove debris. Install an inline strainer to stop further blockages
	Flow regulators may be blocked	Remove flow regulators from inlet and remove debris
	Mains supply is turned off	Turn on mains supply

WARRANTY

Galvin Engineering products are covered under our Manufacturer's Warranty. Galvin Engineering products must be installed in accordance with the installation instructions and in accordance with AS 3500 and NCC Volume Three, relevant Australian Standards and local authorities applicable to product being installed. Water and electrical supply conditions must also comply to the applicable national and/or state standards, failing to comply with these provisions may void the product warranty and affect performance of the product.

Please visit www.galvinengineering.com.au to view the full warranty, our Installation Compliance and Maintenance & Cleaning information as well as any other additional information.